

DATE	SYM	REVISION RECORD	ECO	DWN	ENG	MFG
10/08/2021	00	INITIAL RELEASE	0094	JS	EB	SL

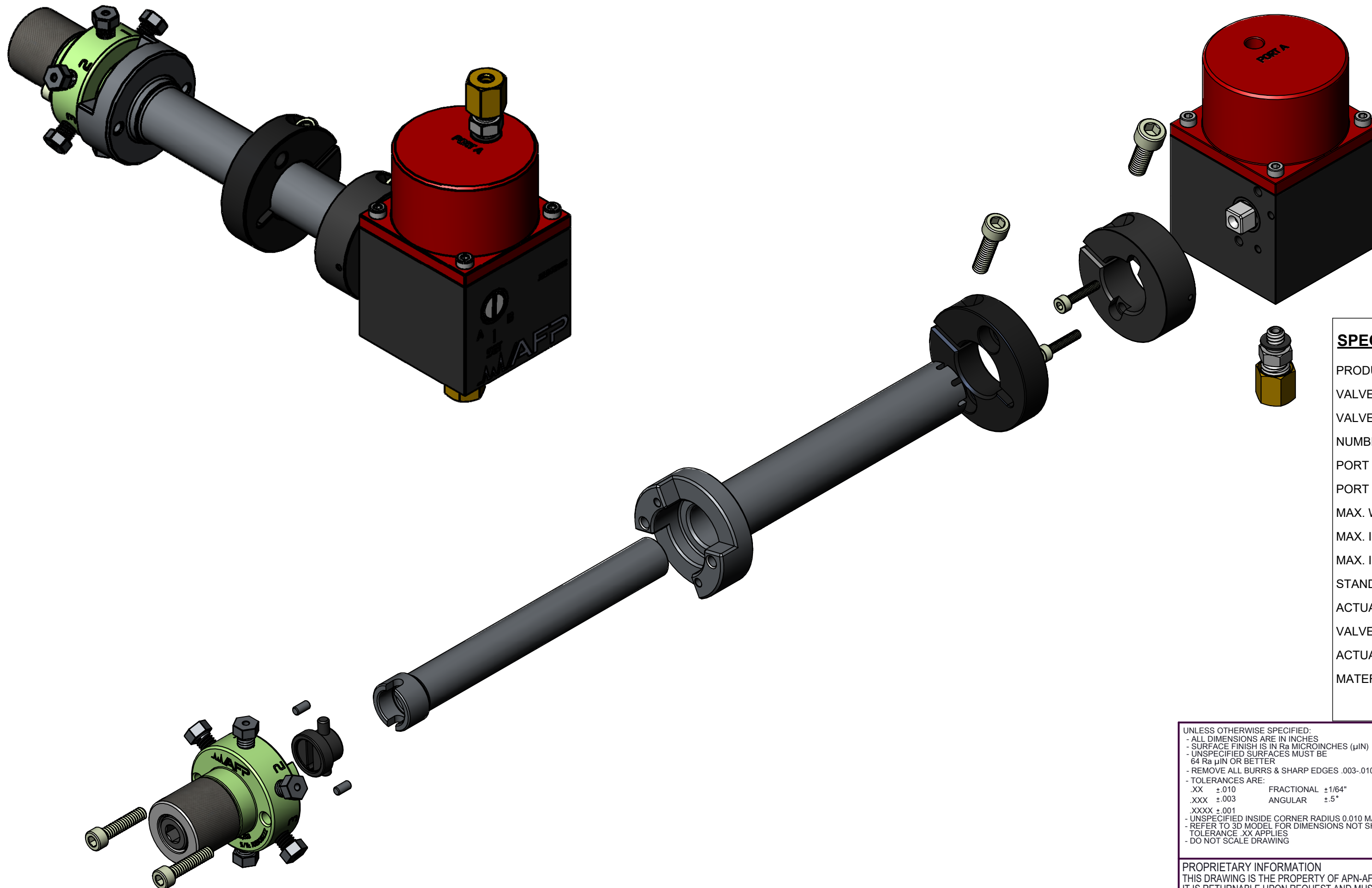
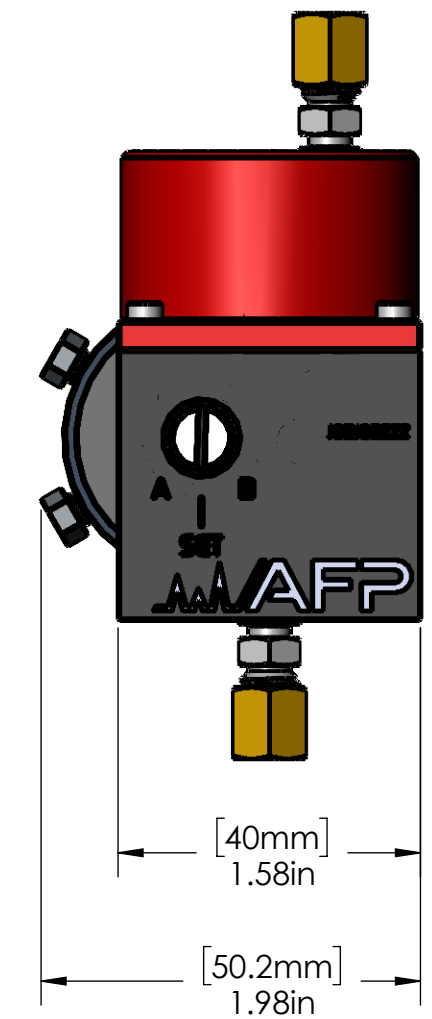
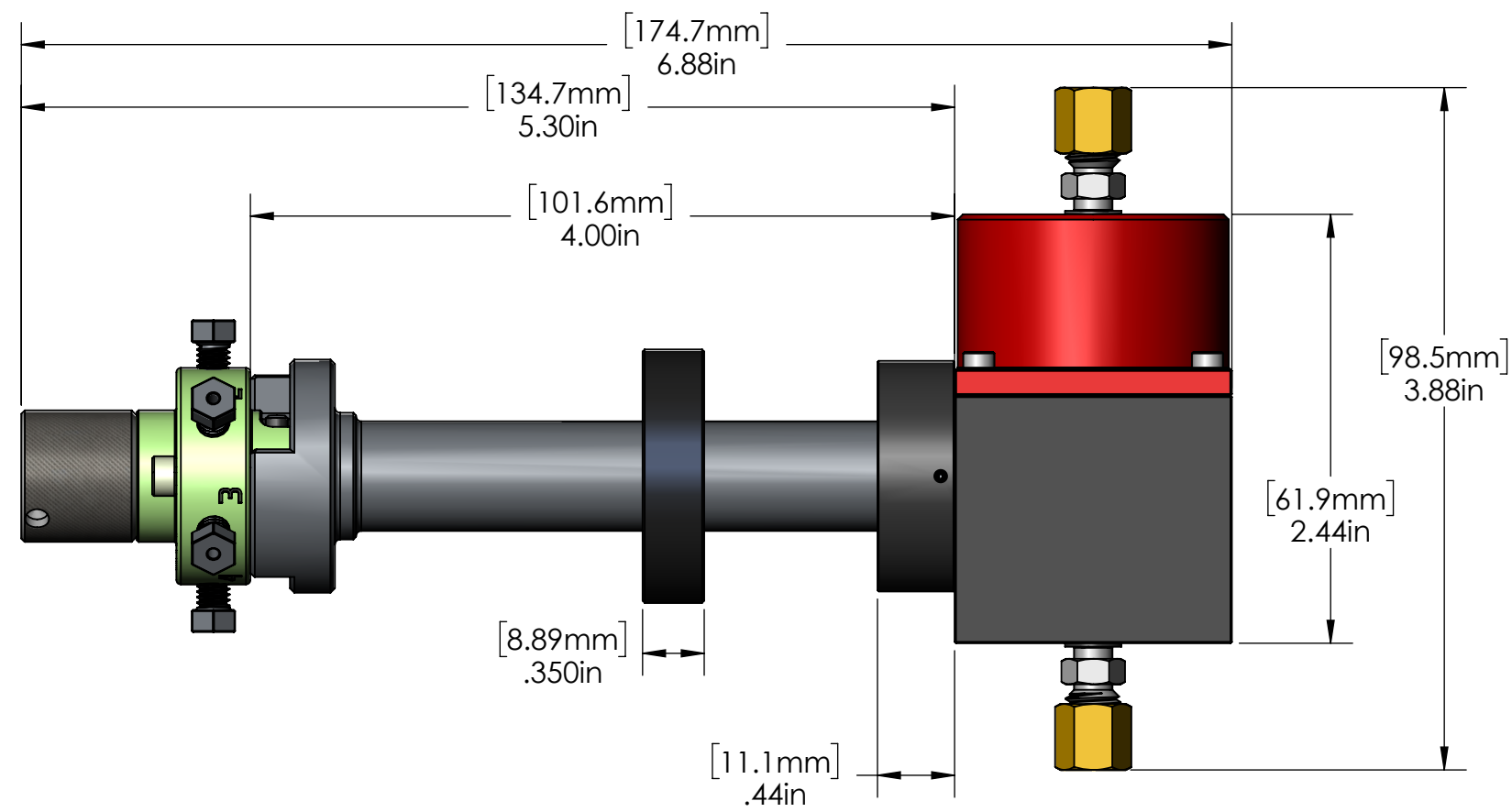

SPECIFICATIONS:

PRODUCT P/N	MRV06-16R2-0006-4P
VALVE P/N	MRV06-16R2-0006
VALVE TYPE	HIGH PERFORMANCE GRADE, MEDIUM TEMPERATURE
NUMBER OF PORTS	6
PORT SIZE	0.025" [0.64 mm]
PORT CONNECTION	1/16" [1.6 mm]
MAX. WORKING PRESSURE	400 psig [2930 kPa]
MAX. INITIAL LEAK RATE	8.5E-10 Atm-cc/s He
MAX. INITIAL PRESSURE DROP	2 kPa @ 75 scfm N ₂ , max. 1 kPa between any sections
STAND-OFF LENGTH	4" [101.6 mm]
ACTUATOR PRESSURE INLET	40 psig [275 kPa] min., 80 psig [550 kPa] max.
VALVE MAX. WORKING TEMPERATURE	437°F [225°C]
ACTUATOR MAX. WORKING TEMP.	257°F [125°C]
MATERIAL	NITRONIC 60 VALVE STATOR DURSAN COATED R2 ROTOR TYPE (MODIFIED PEEK)

UNLESS OTHERWISE SPECIFIED:
 - ALL DIMENSIONS ARE IN INCHES
 - SURFACE FINISH IS IN Ra MICRONS (µIN)
 - UNSPECIFIED SURFACES MUST BE 64 Ra µIN OR BETTER
 - REMOVE ALL BURRS & SHARP EDGES .003-.010
 - TOLERANCES ARE:
 .XX ±.010 FRACTIONAL ±1/64"
 .XXX ±.003 ANGULAR ±5°
 .XXXX ±.001
 - UNSPECIFIED INSIDE CORNER RADIUS 0.010 MAX.
 - REFER TO 3D MODEL FOR DIMENSIONS NOT SHOWN.
 - TOLERANCE .XX APPLIES
 - DO NOT SCALE DRAWING

MATERIAL:

 FINISH:
 MS-1021

 ACCORDANCE WITH
 ASME Y14.5 2018

2659, boul. du Parc Technologique,
 Quebec,
 Quebec, CANADA
 G1P 4S5
 Tel: 418-338-0004
 Email: info@alproducts.ca
 Web: www.alproducts.ca



DESCRIPTION: MRV6 DURSAN MPA 4" ASSEMBLY

PROPRIETARY INFORMATION
 THIS DRAWING IS THE PROPERTY OF APN-AFP INC.
 IT IS RETURNABLE UPON REQUEST AND MUST NOT BE REPRODUCED
 OR THE INFORMATION CONTAINED HEREIN TRANSMITTED TO ANY
 UNAUTHORIZED PERSON OR ORGANIZATION WITHOUT THE
 WRITTEN CONSENT OF APN-AFP INC.

UNIT	SIZE	DWG. NO.	REV.
IN	C	MRV06-16R2-0006-4P	00
SCALE	1	SHEET 1 OF 2	