



High Temperature Sampling & Switching Rotary Valves

MRV-HT Series

The MRV-HT high-performance rotary valve extends your chromatography applications up to 350°C. The rotor (R3) in the MRV-HT is constructed with a PFAS-free high-temperature polyimide/ graphite composite. This rotary valve solves the common issues of current high-temperature valves, sudden failures due to rotary stripping, and while eliminating complex reconditioning procedures.

The MRV-HT Advantages

- Ideal for applications that require temperatures in the range of 225°C to 350°C, with the optimal temperature being 330°C
- Allows for up to 50 actuation cycles at room temperature without damaging the rotor/sealing for instrument tuning and leak testing
- No reconditioning is required to tune the system, which leads to faster installation times
- Compatible with AFP pneumatic actuators and electrical actuators (MEA-I) in an assembly using a standoff
- 6 or 10 port
- Certified up to 300 psi gas
- PFAS Free

The MRV-HT Extended Advantages

- Hexagonal preload design for improved maintenance.
- Extended lifetime: more than 80,000 cycles at 330°C.
- Capable to extend the temperature range of operation: 80°C – 350°C.

Dimensional Information

The **Standard MRV-HT** model is designed for instruments where the drop-in-replacement factor is critical. When the dimensions are not the limiting factor and there is clearance on the length of the valve, the **Extended model** can be used, as it will provide additional range of temperature and extended lifetime.

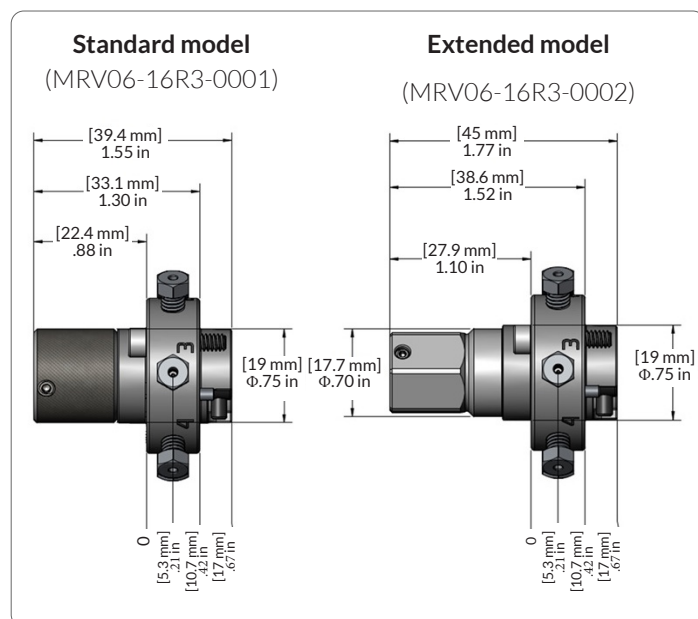

SHOP NOW

Visit our website at
afplifesciences.com



Increased Productivity for Gas Analysis

The ideal temperature for the MRV-HT valve in terms of lifetime value is 330°C, but the MRV-HT can perform at higher temperatures of up to 350°C with only a 15% reduction of service in the lifetime tests. In a comparative study of AFP's MRV-HT with a similar high-temperature valve currently on the market, the R3 rotor achieves almost four times more actuation cycles than its competitor at the maximal continuous operation temperature that the competitor's valve can withstand (330°C). With the addition of the Extended MRV-HT model, the lifetime of the high temperature valves is further pushed to another level. This new model is capable to achieve more than 10 times what the common high temperature valves can do.

Lower Total Cost of Ownership

The R3 rotor's material was selected by AFP to allow end users to turn off the oven and resume their analytical analyses without compromising performance. The MRV-HT's hexagonal preload design improves access to the rotor, speeds up the maintenance process, and reduces instrument downtime.

Extensive cycling at temperatures below 225°C are not advantageous for the MRV-HT rotor, as its performance does not compare to the medium temperature rotor (AFP-R2).

AFP recommends the usage of the MRV-HT valve at applications with temperatures higher than 225°C to obtain its full benefit.

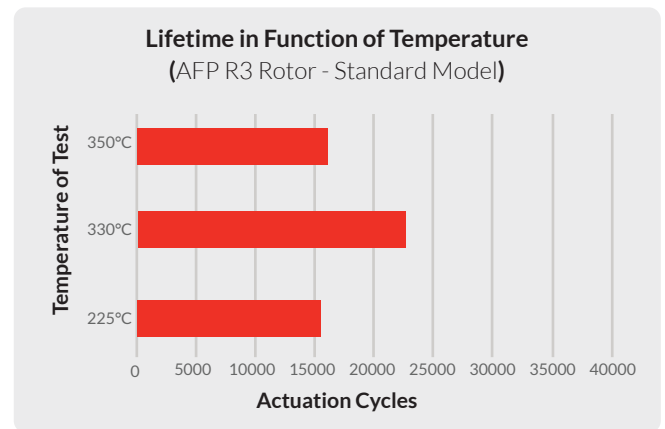
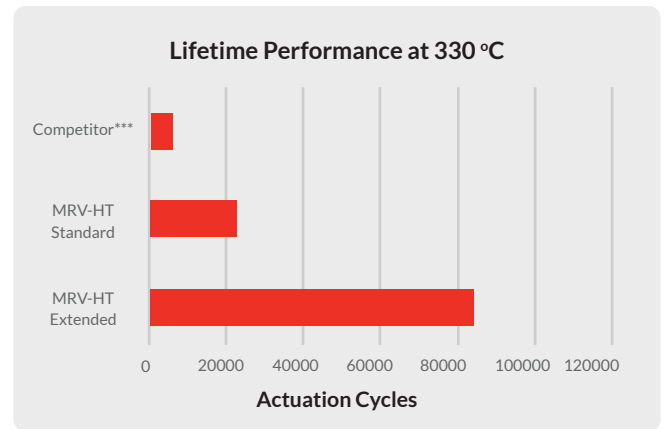

MRV-HT High Temperature Rotary Valves and Replacement

Product Description	AFP SKU	Competitor SKU
High Temperature Rotary Valve 6 Ports 350°C Nitronic 60 325 PSI <i>Assembled On A Pneumatic Actuator With A 4" Standoff</i>	MRV06-16R3-0001-4P	A4C6UWT
High Temperature Rotary Valve 6 Ports 350°C Nitronic 60 325 PSI <i>Assembled On An Electronic Actuator With A 4" Standoff</i>	MRV06-16R3-0001-4I	EUD-4C6UWT
High Temperature Rotary Valve 6 Ports 350°C Nitronic 60 325 PSI	MRV06-16R3-0001-00	DC6UWT
High Temperature Replacement Rotor 6 Ports	MRV-ROT06-R3	SSAC6UWT
High Temperature Rotary Valve 10 Ports 350°C Nitronic 60 325 PSI <i>Assembled On A Pneumatic Actuator With A 4" Standoff</i>	MRV10-16R3-0001-4P	A4C10UWT
High Temperature Rotary Valve 10 Ports 350°C Nitronic 60 325 PSI <i>Assembled On An Electronic Actuator With A 4" Standoff</i>	MRV10-16R3-0001-4I	EUD-4C10UWT
High Temperature Rotary Valve 10 Ports 350°C Nitronic 60 325 PSI	MRV10-16R3-0001-00	DC10UWT
High Temperature Replacement Rotor 10 Ports	MRV-ROT10-R3	SSAC10UWT
High Temperature Rotary Valve, Extended version 6 Ports 350°C Nitronic 60 325 PSI	MRV06-16R3-0002-00	N/A
High Temperature Rotary Valve, Extended version 10 Ports 350°C Nitronic 60 325 PSI	MRV10-16R3-0002-00	N/A