

DATE	SYM	REVISION RECORD	ECO	DWN	ENG	MFG
2018-03-08	00	INITIAL RELEASE	0088	AC	AC	SL
2019-04-08	01	COMPONENT UPDATE	0107	AC	AC	SL

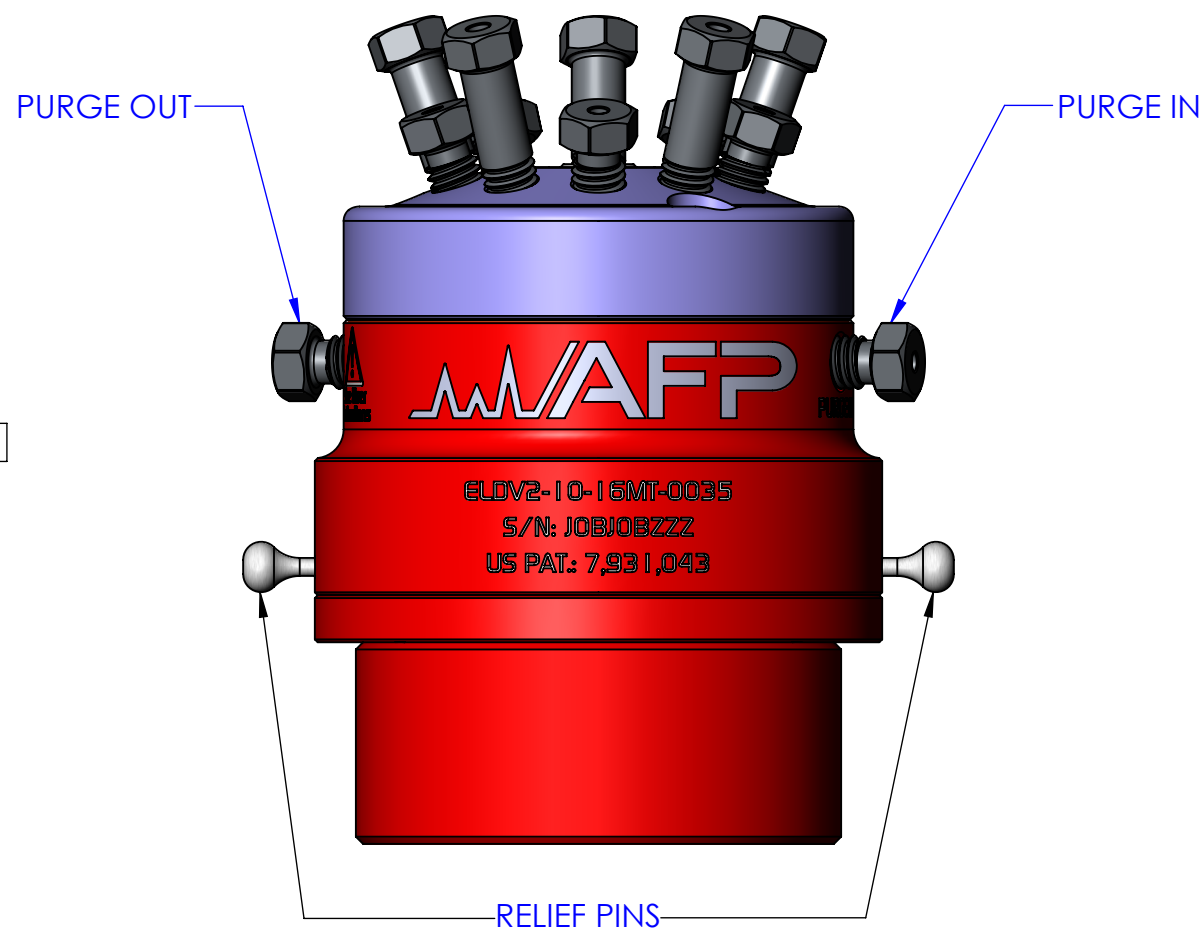
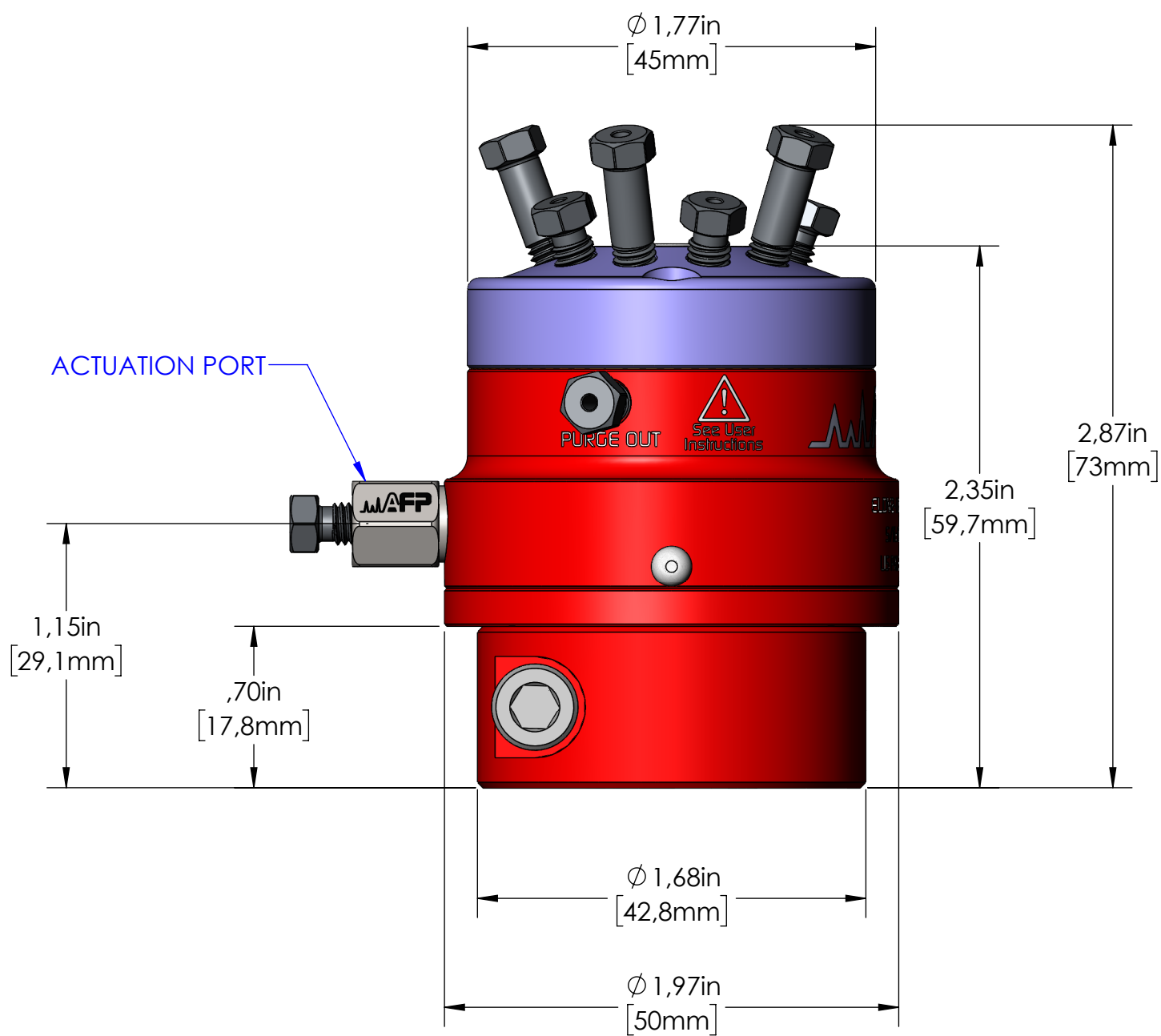
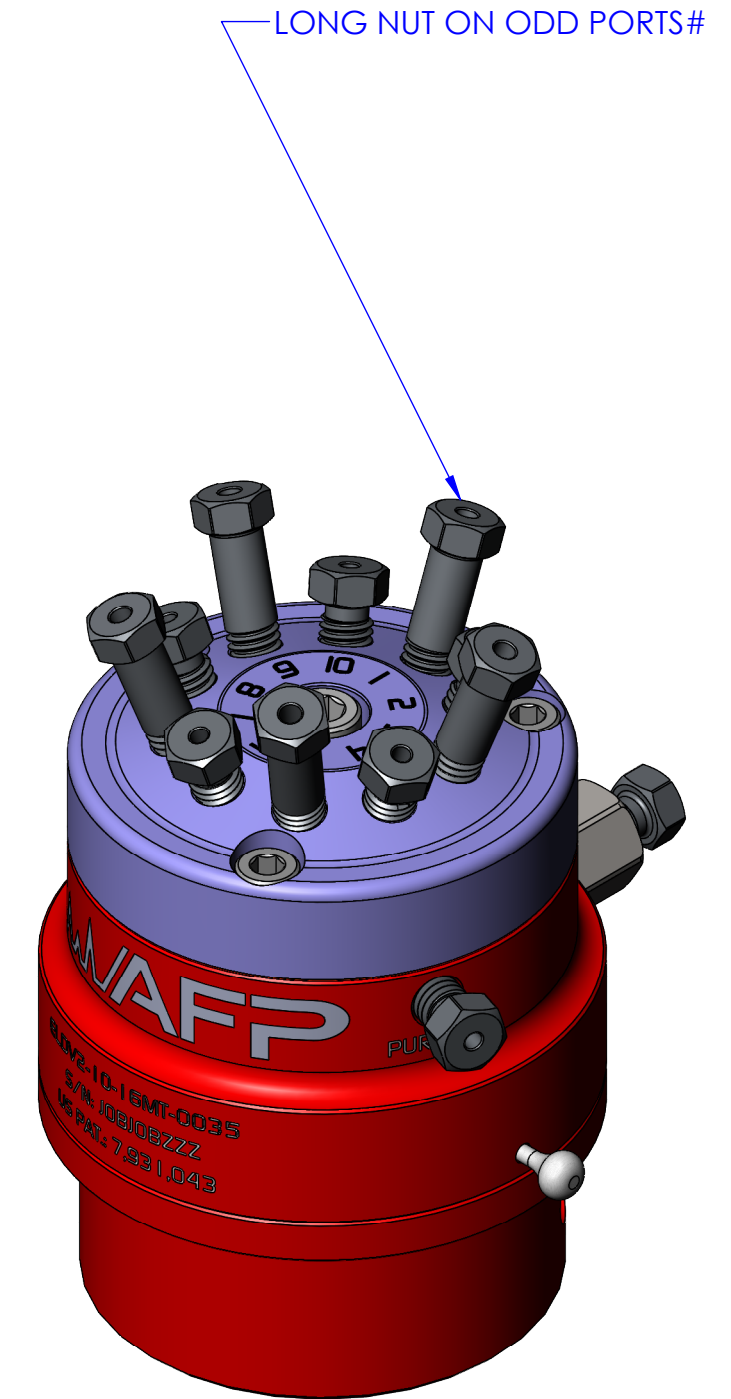
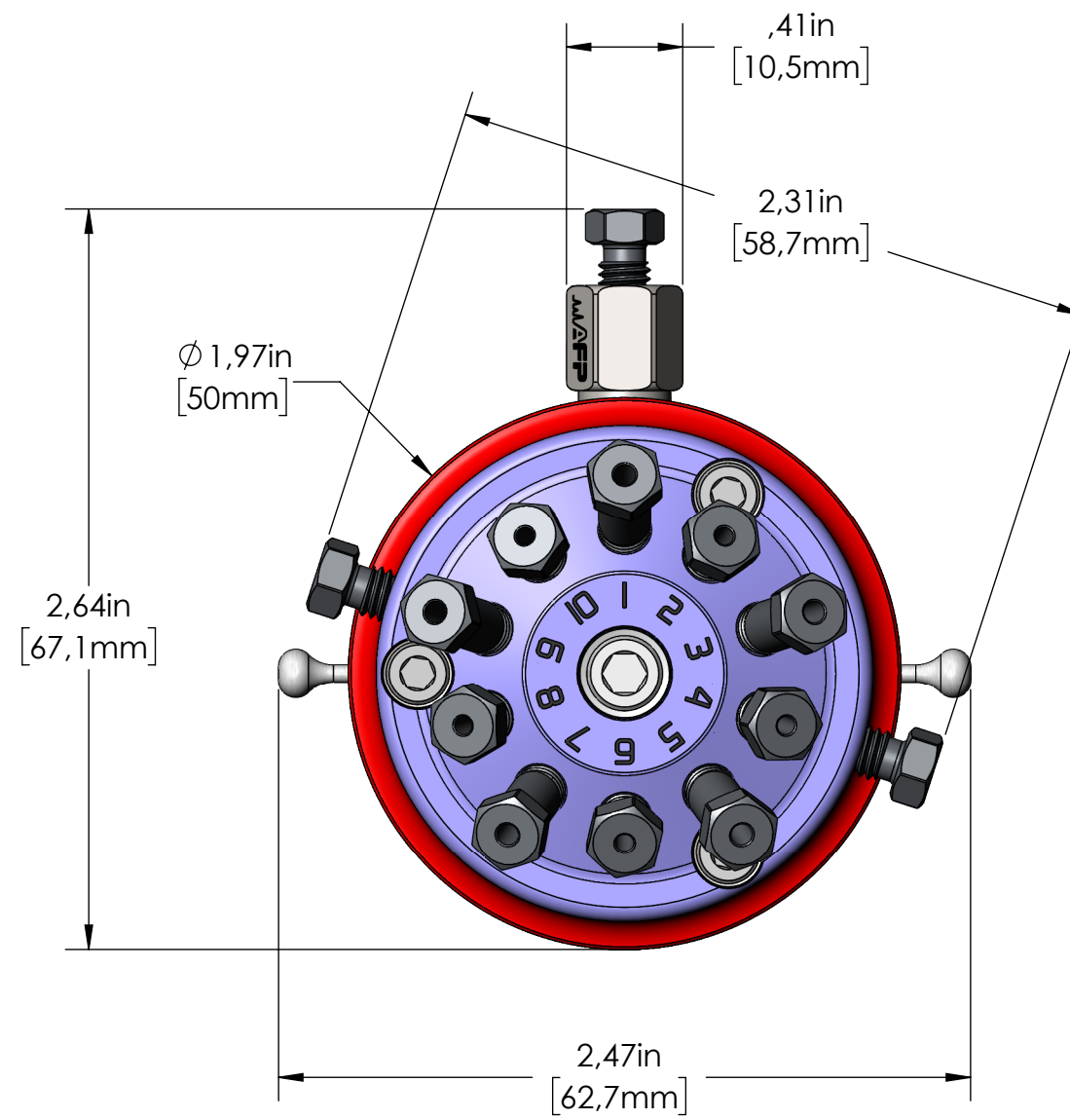

SPECIFICATIONS:

VALVE P/N	-----ELDV2-10-16MT-0035
VALVE TYPE	-----HIGH PERFORMANCE GRADE, MEDIUM TEMPERATURE
NUMBER OF PORTS	-----10
PORT SIZE	-----0.030" [0.76 mm]
PORT CONNECTION	-----1/16" [1.6 mm]
MAX. WORKING PRESSURE	-----300 PSIG [2070 kPa]
MAX. INITIAL LEAK RATE	-----4.1E-10 Atm-cc/s He
MAX. INITIAL PRESSURE DROP	-----30 kPa @ 75 sccm N ₂ , delta max. 15 kPa between any sections
ACTUATOR TYPE	-----PNEUMATIC SINGLE ACTUATION (SPRING RETURN)
ACTUATION PRESSURE	-----65 PSIG [450 kPa]
GAS CONSUMPTION PER ACTUATION	-----0.07 in ³ [1.15 ml]
MAX. WORKING TEMPERATURE	-----356°F [180°C]
MATERIAL	-----ALUMINUM BODY SILCONERT 2000 COATED SS-316L VALVE HEAD AFPD-2 DIAPHRAGM TYPE

MATERIAL: FINISH: ACCORDANCE WITH LATEST ASME Y14.5	2659, boul. du Parc Technologique, Quebec, CANADA G1P 4S5 Tel: 418-338-0004 Fax: 418-338-2500 Email: info@alproducts.ca Web: www.alproducts.ca			
	DESCRIPTION: SILCONERT 2000 MIX NUTS 300PSIG			
PROPRIETARY INFORMATION THIS DRAWING IS THE PROPERTY OF APN-AFP INC. IT IS RETURNABLE UPON REQUEST AND MUST NOT BE REPRODUCED OR THE INFORMATION CONTAINED HEREIN TRANSMITTED TO ANY UNAUTHORIZED PERSON OR ORGANIZATION WITHOUT THE WRITTEN CONSENT OF APN-AFP INC.	UNIT IN	SIZE C	DWG. NO. ELDV2-10-16MT-0035	REV. 01
SCALE 1.5:1		SHEET 1 OF 3		